



JVC[®]

The Perfect Experience / —

D-ILA[®] HD Projection Systems

DLA-HD10K
DLA-HD10KS

D-ILA[®]

Native 1080p
High-Definition

Images with Superb Colour Reproduction

In today's demanding industrial environment, precision and accuracy are critical. Under these conditions, high-definition imaging is a natural fit for demanding industrial users and JVC's high-definition projection systems are the natural choice. Thanks to our original D-ILA device, these projectors deliver full HD resolution pictures with pristine, film-like quality and excellent colour reproduction. With picture reproduction as real and as accurate as life itself, these projectors are ideal for analysis, inspection and other applications in a wide range of industrial fields.

Sleek Design and Easy Setting

With their stylish, symmetrical designs and sleek aluminium frames, JVC's HD projectors make an attractive addition to any interior environment. Tough enough and durable enough to withstand the rigours of industrial use, these projectors offer extremely flexible installation capability, making them ideal for use in design studios, post-production studios, museums or mini theatres. All models feature a lens shift function for versatile positioning and both long-focus and short-focus models are available.

Film-like Images and Excellent Colour Reproduction

■ 3 D-ILA chip imaging with native 1080p resolution

JVC's D-ILA imaging chips feature native 1920 x 1080 resolution and utilise "Non-Moving" mirror reflective technology to produce the full HD resolution you need for critical image display applications.



HD D-ILA device

■ Smooth picture/D65 colour temperature

At only 0.45µm, the gaps between pixels are so narrow that no grids appear on the picture surface. As a result, the outlines of people, animals, and other objects are extremely smooth and natural. Reference standard D65 colour temperature ensures accurate colour reproduction of video,



With a pixel gap of only 0.45µm, a smooth picture with no visible grid is obtained.

CG, or film-originated programming. D65 performance and dynamic range is adjusted by an illumination system with RGB-optimised f-number.

Thanks to the proven reliability of JVC's optical engine design and Dynamic Square Aperture, high contrast of 2500: 1 is achieved in all modes from Wide to Tele.

Advantages of 3-chip D-ILA technology

JVC's original D-ILA technology

- **Three D-ILA chips for smooth, flicker-free high-resolution images**
JVC's original 3-chip D-ILA (Direct Drive Image Light Amplifier) technology produces clear, natural images without the annoying flicker or "rainbow effect" that plagues single panel projectors. Images are as smooth as film, boasting incredible detail.
- **Cinema-quality picture with no visible grid**
There is no visible grid or "screen door effect" with JVC's D-ILA so you can enjoy the beauty of film-like resolution.
- **Professional-standard grey scale reproduction**
JVC's exclusive AG (Analogue Gradation) technology produces highly accurate gradations with low noise, particularly in darker areas with less than 20% brightness. The quality of grey-scale reproduction is further enhanced by high 2500:1 contrast that ensures high-precision, high-quality pictures without black paint even when the scene on screen is dark.
- **Superior colour reproduction**
JVC's unique optical engine produces rich, natural colours with smooth gradations and low noise. Colour temperature is set at 6500K, providing optimal cinema-style reproduction. As the D-ILA's liquid crystals are aligned vertically, the pixels are "normally black" when no voltage is applied. As a result, D-ILA technology reproduces blacks that are truly black. It also offers a uniform response, irrespective of brightness, displaying a wide range of intermediate tones.

● DLA-HD10K /HD10KS Colour Coordinates

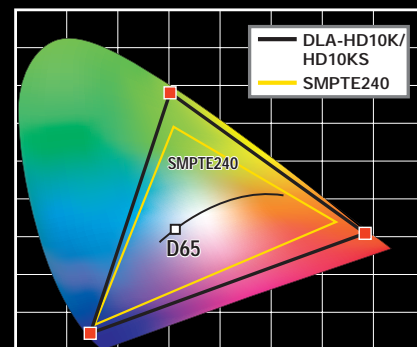

● Comparison of gradation characteristics



(accurate colours with absolute white and black)



Conventional projector (bluish white and reddish black)

DILA®



Demand the Best —

Incomparable Big-Screen High-Definition Image Projection

Wide Range of Applications



■ CAD system for auto manufacturer and industrial design



■ Preview system for film production and mini theatre

Convenient 2-Piece Installation

The lightweight 17 kg projector is set up in the viewing room, while the critical digital video processor is mounted in the equipment rack adjacent to the video sources or a PC. Only one DVI interface cable (max. 10 m) or optical conversion cable (10 m, 20 m, 30 m) is required between the processor and projector, ensuring that maximum signal integrity is maintained.

Two Processors Available

Two types of processor are available. One is an AV hub processor that allows you to connect a variety of audio and video equipment including a PC*. The other is a high-performance high-end digital video processor designed for the most quality-critical imaging applications. Simply choose the one most appropriate to your needs.

*AV hub processor can be connected to a PC, however, the digital video processor cannot.

AV hub processor system diagram

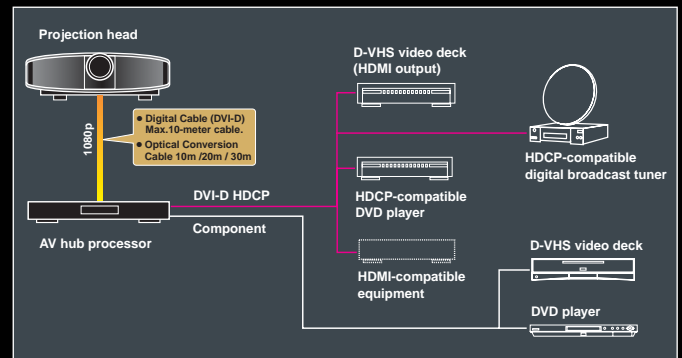

LD-HD1K AV hub processor

This is an excellent cost/performance model with superior operability. 7 video inputs and 4 HDMI connectors are provided. In addition, a selector can be used and audio signals can be switched with the digital audio input connector.

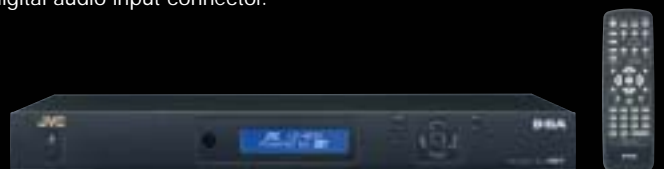



- 3D system for amusement company and university
- HD still picture system for museum and 3D pictures with the stacked DLA-HD10 projectors



- Post production and broadcasting



LD-HD2K digital video processor

This is a high-performance Faroudja-manufactured model that sends optimised video signals to the projection head. Ready for 1080p throughput. Faroudja's highly reputed DCDI high-quality picture circuit, MADI (motion-compatible technology) and 3:2 pull-down function are incorporated.

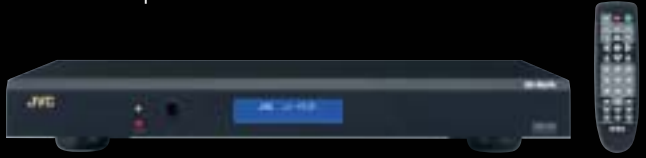

Flexible Installation

To accommodate the widest range of rooms, two models are available, each offering a different range of lens throw distances. The DLA-HD10KS has a lens throw ratio of 1.5 – 2.1:1, while the DLA-HD10K has a lens throw ratio of 2.0 – 3.8:1. Precision high-resolution all-glass lenses with motorised zoom and focus make installation a snap, while installation flexibility is further enhanced by lens shift capability. This allows the light path to be adjusted according to the installation position, even when installed on a ceiling or table.

Low Fan Noise Design

Any external noise can be annoying in a quiet room. That's why JVC has developed an original new airflow design that provides optimum cooling while keeping the noise level down to a near silent 27 dB. Thanks to this low fan noise design, these projectors are suitable to various applications and working styles.

Cost-effective NUP Lamp

To keep running costs down, the DLA-HD10K/10KS projector uses a low-cost, long-life 200 W NUP lamp. The lamp can be easily replaced without removing the projector from the ceiling, and should be replaced approximately every 2000 hours.



Specifications

Projectors	
Image Device	3-chip D-ILA® (0.82-inch diagonal)
Aspect Ratio	16:9
Throw Distance (16:9)	Short focus: 1.9 m to 9.3 m (6.43 ft to 30.57 ft) Long focus: 2.5 m to 15.0 m (8.46 ft to 49.23 ft)
Screen Size (16:9)	60" to 200" diagonal
Resolution	1920 x 1080 pixels (16:9) x 3 chips; Total resolution: 6,220,800 pixels
Projection Lens	Short focus: 1.4X zoom lens (1.5 – 2.1:1) Long focus: 1.9X zoom lens (2 – 3.8:1) Power zoom/focus, 0 - 60% offset with manual shift
Lamp	200 W NUP
Contrast Ratio	2500:1
Colour Temperature	D65/user selectable 1/user selectable 2
Gamma Control	Normal, A, B, and CUSTOM
Noise Level	27 dB
TERMINALS	
Input	Digital x 1 (HDCP compatible DVI-D)
Serial Control	RS-232C x 1, screen trigger (12 V) x 1, service x 1
GENERAL	
Power Requirement	100 V – 240 V AC, 50/60 Hz
Power Consumption	320 W (5 W at standby)
Calorific Power	1152 kJ/h (1092 Btu)
Dimensions (WHD)	513 x 193.7 x 558.5 mm without protrusions
Weight	Approx. 17 kg

Digital Video Processors

	LD-HD1K AV hub processor	LD-HD2K digital video processor
Input Signals	480/60i, 480/60p, 576/50i, 576/50p, 720/50p, 60p, 1080/50i, 60i, VGA, SVGA, XGA, SXGA (60 Hz)	480/60i, 480/60p, 576/50i, 576/50p, 720/50p, 60p, 1080/50i, 60i, 1080/50p, 60p (through)
TERMINALS		
Input Terminals	RGB x 1 (BNC: Common use for component), HDMI x 4 (HDCP-compatible), Component x 3 (RCA x 2, BNC x 1: Common use for RGB), Composite x 2 (RCA), S-Video (Y/C) x 2	RGBC (BNC) x 1 (Common use for YPbPr), DVI (HDCP compatible DVI-D) x 1, Video (BNC) x 1, Y/C (Mini DIN) x 1, YPbPr (BNC) x 1 (Common use for RGBC),
Video Output Signals	1080/60p, 1080/50p	DVI (HDCP compatible DVI-D) x 1*
Video Output Terminals	HDMI x 1 (HDCP-compatible)	* Terminals other than DVI are not used for D-ILA HD Projection System.
Audio Input Terminals	Digital (Coaxial) x 2, Digital (Optical) x 2, Analogue (RCA) x 1, HDMI x 4 (Common use with video input terminal)	
Audio Output Terminals	Digital (Coaxial) x 1, Digital (Optical) x 1	
Control Terminals	RS-232C (D-sub 9-pin) x 1	RS-232C (D-sub 9-pin) x 1, DC 12 V trigger terminal (mini jack) x 1
GENERAL		
Power Requirement	100 V – 240 V AC, 50/60 Hz	
Power Consumption	30 W	35 W
Dimensions (W x H x D)	434 x 46 x 263 mm without protrusions	438 x 45 x 303 mm without protrusions
Weight	4.8 kg	6.3 kg

Throw Distance vs. Screen Size

Screen Size			Short-focus Zoom (1.5 to 2.1: 1 lens, aspect ratio: 16:9)				Long-focus Zoom (2.0 to 3.8, aspect ratio: 16:9)			
			Wide		Tele		Wide		Tele	
Diagonal	Width	Height	m	ft.	m	ft.	m	ft.	m	ft.
60	1328	4.36	1.96	6.43	2.77	9.09	2.58	8.46	4.94	16.20
70	1550	5.08	2.29	7.51	3.23	10.59	3.02	9.91	5.78	18.96
80	1771	5.81	2.63	8.63	3.70	12.14	3.46	11.35	6.62	21.71
90	1992	6.53	2.96	9.71	4.17	13.68	3.90	12.79	7.46	24.47
100	2214	7.26	3.29	10.79	4.64	15.22	4.34	14.24	8.30	27.22
110	2435	7.99	3.63	11.91	5.11	16.76	4.79	15.71	9.14	29.98
120	2657	8.71	3.96	12.99	5.57	18.27	5.23	17.15	9.98	32.73
130	2878	9.44	4.29	14.07	6.04	19.81	5.67	18.60	10.82	35.49
140	3099	10.16	4.63	15.19	6.51	21.35	6.11	20.04	11.65	38.21
150	3321	10.89	4.96	16.27	6.98	22.89	6.55	21.48	12.49	40.97
160	3542	11.62	5.30	17.38	7.45	24.44	6.99	22.93	13.33	43.72
170	3764	12.35	5.63	18.47	7.91	25.94	7.43	24.37	14.17	46.48
180	3985	13.07	5.96	19.55	8.38	27.49	7.88	25.85	15.01	49.23
190	4206	13.80	6.30	20.66	8.85	29.03	8.32	27.29		
200	4428	14.53	6.63	21.75	9.32	30.57	8.76	28.73		

Dimensions

Unit: mm (inches)

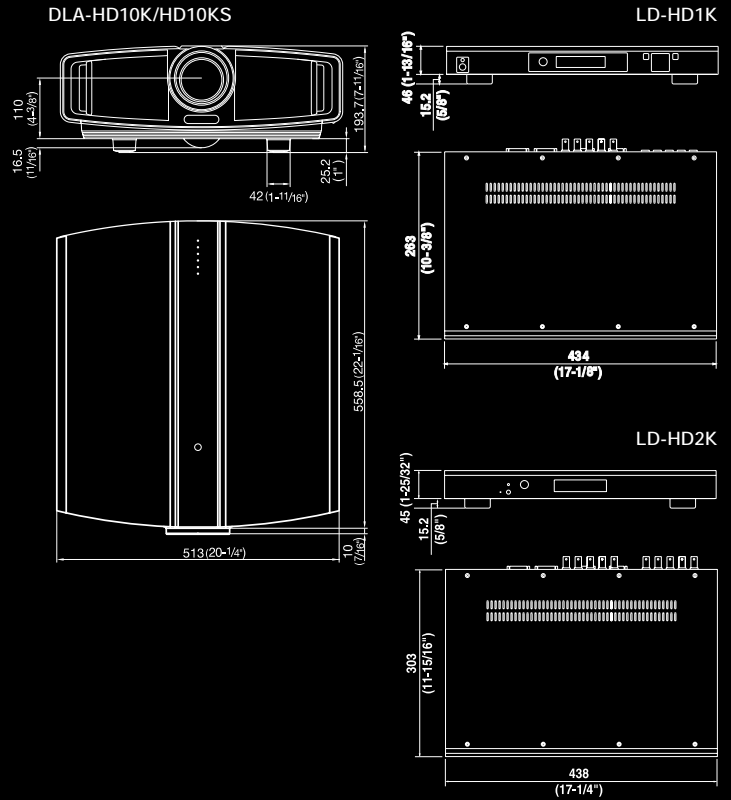

Connectors



Provided accessories

Projector: Instructions, power cord, remote control (RM-MH10K), two AA batteries, warranty card

LD-HD2K: Instructions, Power Cord, DVI-D Cable (5 m), Remote Control, Two Size AA Batteries, Warranty Card

LD-HD1K: Instructions, Power Cord, DVI-HDMI Cable (5 m), Remote Control, Two Size AA Batteries, Warranty Card

JVC®

DISTRIBUTED BY

Design and specifications subject to change without notice.
D-ILA is a registered trademark of Victor Company of Japan, Limited.
All brand or product names may be trademarks and/or registered trademarks of their respective owners.
All rights not expressly granted herein are reserved.
All photographs and screenshots in this catalogue are simulated.
Copyright © 2005, Victor Company of Japan, Limited (JVC). All Rights Reserved.



JVC is the trademark or registered trademark of Victor Company of Japan, Limited.